

AK 45, DN 15, 20, 25 mm **RHOMBUSline**

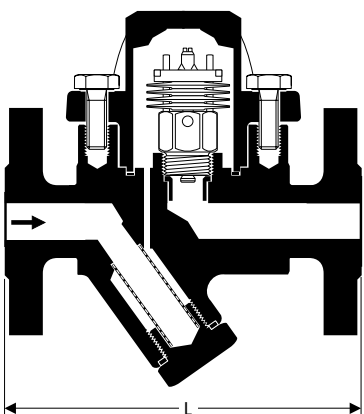

UBK 46, DN 15, 20, 25 mm **RHOMBUSline**

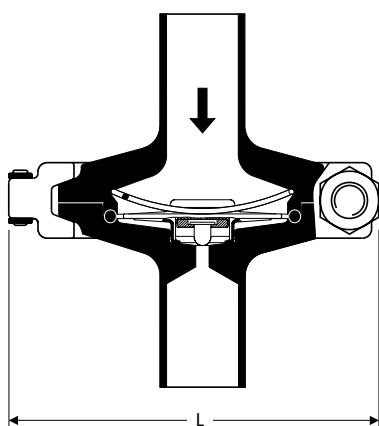

SMK 22, DN 15 mm **STERline**

Application

Type	
AK 45 RHOMBUSline	Condensate drain valve for discharging condensate from steam systems during start-up and draining residual condensate at shut-down, with integral Y-type strainer and hand purging knob. Factory-set closing pressure 0.8 bar.
UBK 46 RHOMBUSline	Steam trap with adjustable condensate discharge temperature, thereby suppressing the formation of flash steam. With Y-type strainer.
SMK 22 STERline STAINLESS STEEL	Steam trap for SIP applications.
MK 20	Steam trap for low-pressure steam-heating installations.
TK 23, TK 24	Steam trap with thermostatic pilot control using thermostatic capsules for the discharge of very large condensate flowrates with relatively continuous condensate formation.
GK 11¹⁾	Thermodynamic steam trap with stage nozzle for the discharge of very large condensate flowrates. With integral Vaposcope (sightglass) for optimum trap adjustment.

¹⁾ DN 50 mm: GK 21

Pressure/Temperature Ratings^{*)}

Type	PN	Δ PMX [bar]	Materials		Max. Pressure/Temperature Rating	
			DIN	ASTM	PMA / TMA	PMA / TMA
AK 45	40		C 22.8 ¹⁾	A 105 ¹⁾	32 bar / 250 °C	21 bar / 400 °C
UBK 46	40	32	C 22.8 ¹⁾	A 105 ¹⁾	32 bar / 250 °C	21 bar / 400 °C
SMK 22 STAINLESS STEEL	10	6	1.4435	–	10 bar / 150 °C	10 bar / 150 °C
MK 20	6	4.5	GTW-40	–	4.5 bar / 250 °C	3.6 bar / 300 °C
TK 23	16	1 – 10	GG-25	A 126 CLB ²⁾	16 bar / 120 °C	10 bar / 300 °C
TK 24	25	1 – 14	GS-C 25	A 216 Gr. WCB ²⁾	25 bar / 120 °C	13 bar / 400 °C
GK 11	16	6	GG-25	A 126 CLB ²⁾	16 bar / 120 °C	13 bar / 300 °C

¹⁾ Material complies with DIN and ASTM requirements.

²⁾ ASTM nearest equivalent grade is stated for guidance only.

Physical and chemical properties comply with DIN grade.

^{*)} For more information see data sheet.

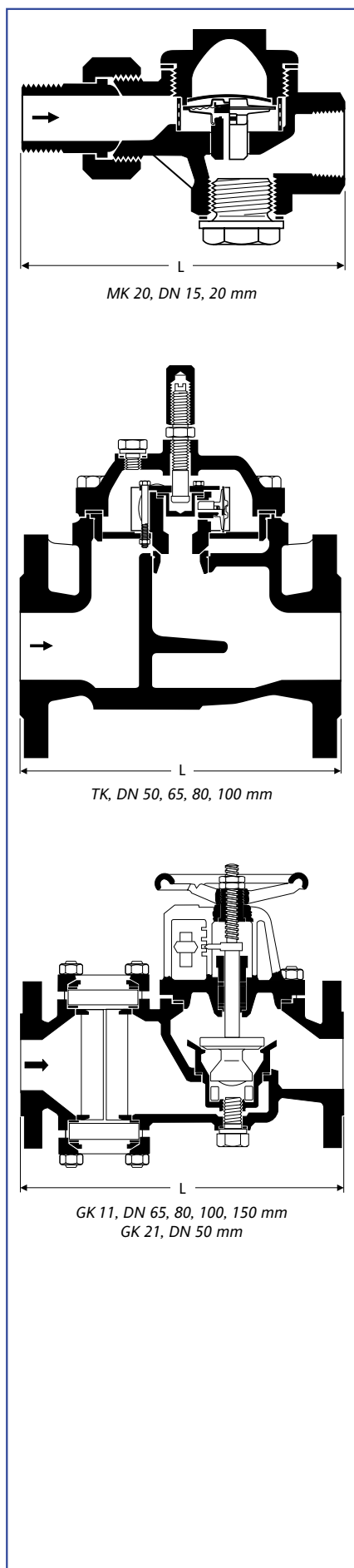

Available End Connections and Overall Lengths

Type	Connection	Overall length (L) in mm							
		DN 15 1/2"	DN 20 3/4"	DN 25 1"	DN 50 2"	DN 65 2 1/2"	DN 80 3"	DN 100 4"	DN 150 6"
AK 45 RHOMBUSline®	Flanged DIN PN 40	150	150	160	–	–	–	–	–
	Flanged ANSI 150	150	150	160	–	–	–	–	–
	Flanged ANSI 300	150	150	160	–	–	–	–	–
	Screwed sockets	95	95	95	–	–	–	–	–
UBK 46 RHOMBUSline®	Flanged DIN PN 40	150	150	160	–	–	–	–	–
	Flanged ANSI 150	150	150	160	–	–	–	–	–
	Flanged ANSI 300	150	150	160	–	–	–	–	–
	Screwed sockets	95	95	95	–	–	–	–	–
	Socket-weld	95	95	95	–	–	–	–	–
SMK 22 STERline® STAINLESS STEEL	Butt-weld	83	–	–	–	–	–	–	–
MK 20¹⁾	Male/female thread	120	125	–	–	–	–	–	–
TK 23	Flanged DIN PN 16	–	–	–	230	290	310	350	–
TK 24	Flanged DIN PN 25	–	–	–	230	290	310	350	–
GK 11²⁾	Flanged DIN PN 16	–	–	–	320	420	420	620	900

¹⁾ Straight-through or angle design (see representation)

²⁾ DN 50 mm: GK 21

Capacity Charts

The charts show the maximum hot condensate capacities. (Exception: AK 45 – cold water capacity.)

AK 45 Cold Water capacity

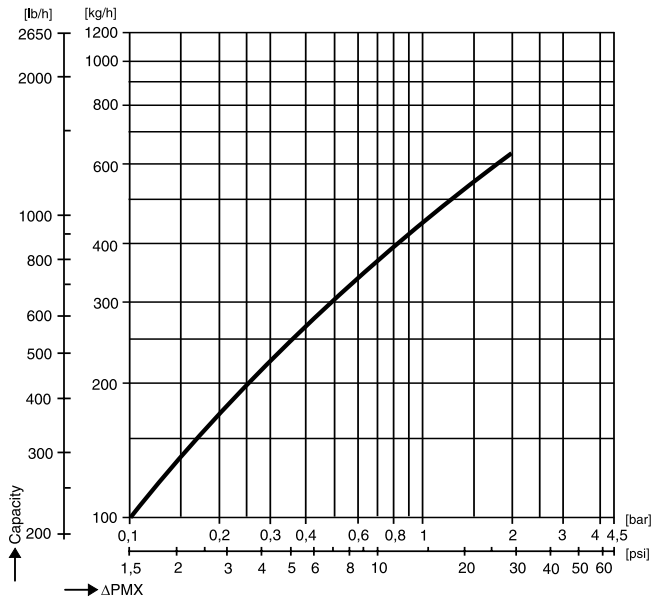

UBK 46

Service pressure (bar)	1	2	4	8	12	16	20	26	32
Opening temperature at factory setting (°C)	72	74	78	85	89	93	97	103	109
Capacity at t 10 K below opening temperature (kg/h)	94	113	136	164	184	198	211	226	239
Cold-condensate capacity at 20 °C (Start-up capacity) (kg/h)	267	390	570	832	1039	1215	1373	1584	1774

SMK 22

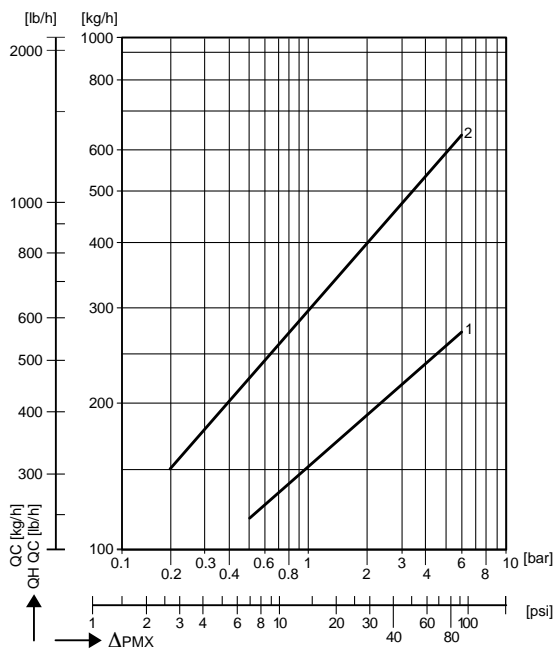

The chart shows the maximum capacities for hot and cold condensate.

Curve 1

This curve indicates the max. capacity of hot condensate that the steam trap with regulating membrane *Steriline* can discharge with virtually no banking up.

Curve 2

This curve shows the max. capacity of cold condensate that the steam trap can discharge (20 °C at start-up).

Capacity Charts

The charts show the maximum hot condensate capacities.

MK 20

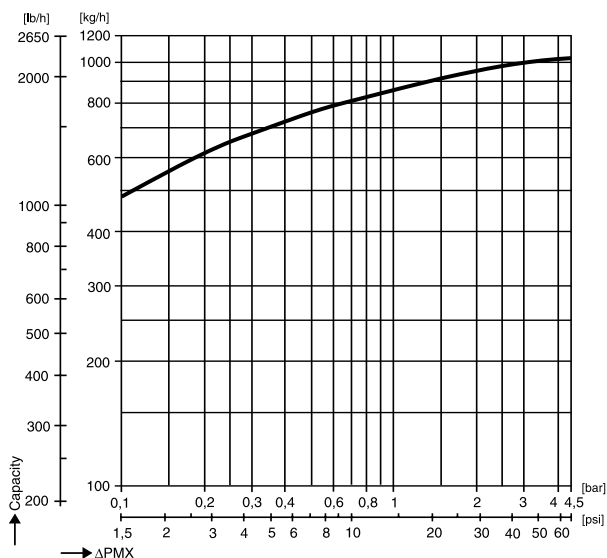

TK 23, TK 24

For differential pressures < 1 bar use capsule "OH2" (max. service pressure 5 bar).

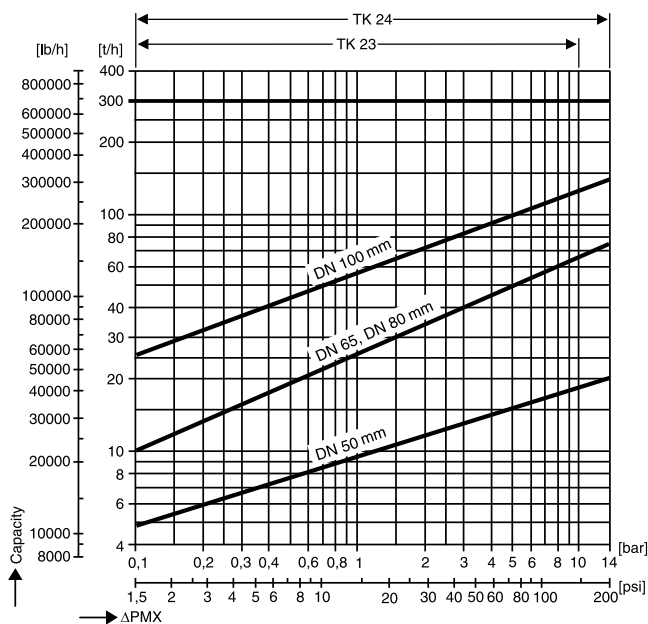

GK 11, GK 21

