

ARI-Check valve, metallic sealing

ARI-Check valve - Straight through with flanges

- TRB 801 Annex II No. 45 (except EN-JL1040)
- German TA - Luft TÜV-Test-No. 922-9204866

Grey cast iron
SG iron
Cast steel
Fig. 003/303

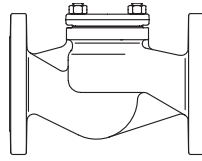

Page 2

ARI-Check valve - Straight through with flanges

- TRB 801 Annex II No. 45
- German TA - Luft TÜV-Test-No. 922-9204866

Forged steel
Fig. 003

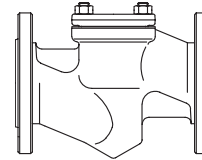

Page 3

ARI-Check valve - Straight through with flanges

- TRB 801 Annex II No. 45
- German TA - Luft TÜV-Test-No. 922-9204866

Stainless steel
Fig. 003

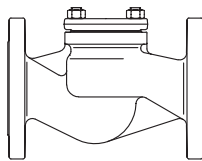

Page 4

ARI-Check valve - Angle pattern with flanges

- TRB 801 Annex II No. 45 (except EN-JL1040)
- German TA - Luft TÜV-Test-No. 922-9204866

Grey cast iron
SG iron
Cast steel
Fig. 004/304

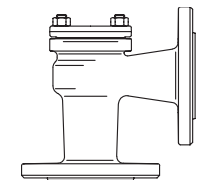

Page 5

ARI-Check valve - Straight through with butt weld ends

- TRB 801 Annex II No. 45
- German TA - Luft TÜV-Test-No. 922-9204866

Forged steel
Fig. 030

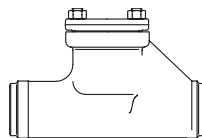

Page 6

ARI-Check valve - Straight through with butt weld ends

- TRB 801 Annex II No. 45
- German TA - Luft TÜV-Test-No. 922-9204866

Cast steel
Fig. 030

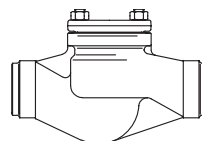

Page 7

ARI-Check valve - Y-pattern with flanges

- TRB 801 Annex II No. 45
- German TA - Luft TÜV-Test-No. 922-9204866

Stainless steel
Fig. 039

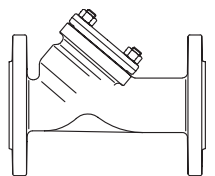

Page 8

ARI-Check valve - Y-pattern with butt weld ends

- TRB 801 Annex II No. 45
- German TA - Luft TÜV-Test-No. 922-9204866

Cast steel
Fig. 063

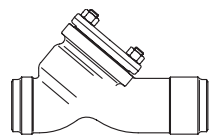

Page 9

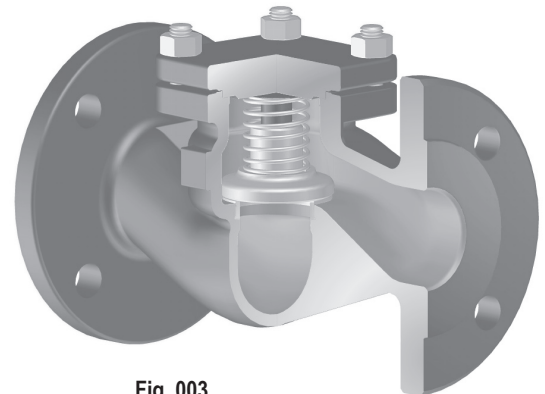

Fig. 003

Features:

- Solid plug made of stainless material
- Solid seat made of stainless material
- Re-setting spring made of stainless steel
- Precise plug guidance

Check valve - straight through with flanges (Grey cast iron, SG iron, Cast steel)

Figure	Nominal pressure	Material	Nominal diameter
10.003	PN6	EN-JL1040	DN15-200
12.003 / 12.303	PN16	EN-JL1040	DN15-300
22.003 / 22.003	PN16	EN-JS1049	DN15-350
23.003 / 23.303	PN25	EN-JS1049	DN15-150
34.003 / 34.303	PN25	1.0619+N	DN15-500
35.003 / 35.303	PN40	1.0619+N	DN15-500

Set pressure 0,1 bar

Fig. 303: Trim made of RG/MS:

CuZn35Ni3Mn2AlPb, CW710R code number 02

CuSn10-Cu, CC480K code number 03

(max. operating temperature: 225°C, code number acc. to DIN 86251)

Test: • German TA - Luft TÜV-Test-No. 922-9204866

Selection of possible applications

Industry, power stations, flue gas purification plant, vapour facilities, recycling facilities, shipbuilding, general plant manufacturing (other applications on request)

Selection of possible flow media

Steam, gases, liquids, etc. (other flow media on request)

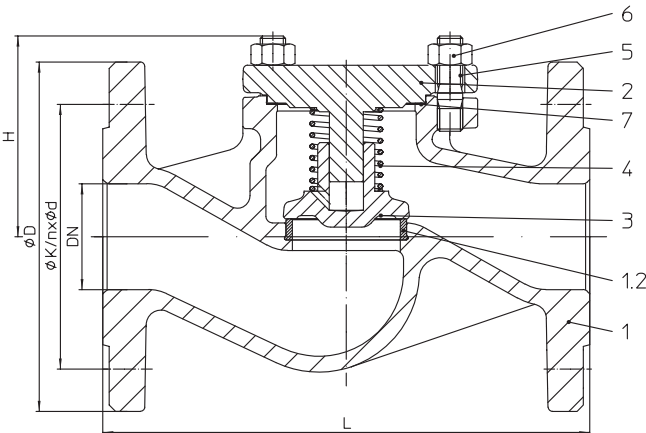
Parts

Pos.	Description	Fig. 10./12.003	Fig. 10./12.303	Fig. 22./23.003	Fig. 22./23.303	Fig. 34./35.003	Fig. 34./35.303
1	Body	EN-JL1040, EN-GJL-250		EN-JS1049, EN-GJS-400-18U-LT		GP240GH+N, 1.0619+N	
1.2	Seat ring	DN ≤50: X20Cr13+QT, 1.4021+QT DN >50: G19 9 Nb Si, 1.4551	CuSn10-Cu, CC480K code number 03	DN ≤50: X20Cr13+QT, 1.4021+QT DN >50: G19 9 Nb Si, 1.4551	CuSn10-Cu, CC480K code number 03	DN ≤50: X20Cr13+QT, 1.4021+QT DN >50: G19 9 Nb Si, 1.4551	CuSn10-Cu, CC480K code number 03
2	Cover	EN-JL1040, EN-GJL-250		EN-JS1049, EN-GJS-400-18U-LT		GP240GH+N, 1.0619+N	
3	Plug	DN ≤200: X20Cr13+QT, 1.4021+QT DN >200: P265 GH, 1.0425 / G19 9 Nb Si, 1.4551		DN ≤200: X20Cr13+QT, 1.4021+QT DN >200: P265 GH, 1.0425 / G19 9 Nb Si, 1.4551		DN ≤200: X20Cr13+QT, 1.4021+QT DN >200: P265 GH, 1.0425 / G19 9 Nb Si, 1.4551	
4	Spring	X10CrNi18-8, 1.4310		X10CrNi18-8, 1.4310			
5	Hexagon bolt	5.6		--			
5	Stud	--		25CrMo4, 1.7218			
6	Hexagon nut	--		C35E, 1.1181			
7	Gasket	Pure graphite (CrNi laminated with graphite)					

Information / restriction of technical rules need to be observed!

Operating instructions can be ordered by phone +49 (0)5207 / 994-0 or fax +49 (0)5207 / 994-158 or -159.

ARI-Valves of EN-JL1040 are not allowed to be operated in systems acc. to TRD 110.

A production allowance acc. to TRB 801 No. 45 exists (acc. to TRB 801 No. 45 EN-JL1040 is not allowed.)

The engineer, designing a system or a plant, is responsible for the selection of the correct valve.

Dimensions

	DN	15	20	25	32	40	50	65	80	100	125	150	200	250	300	350	400	500
L	(mm)	130	150	160	180	200	230	290	310	350	400	480	600	730	850	980	1100	1350
H	(mm)	70	70	80	80	85	95	110	130	155	165	215	285	325	365	420	430	530
Kvs-value	(m³/h)	5,7	7,8	11,8	17,9	27,5	48,0	77,6	109	168	251	389	664	1017	1446	2042	2725	4167
Zeta-value	--	2,5	4,2	4,5	5,2	5,4	4,3	4,7	5,5	5,7	6,2	5,4	5,8	6,0	6,2	5,5	5,3	5,5

Zeta-value ... range of tolerance for Kvs-values acc. to VDI/VDE 2173

Standard-flange dimensions refer to page 11

Face-to-face dimension FTF series 1 according to DIN EN 558-1 (DN500: Face-to-face dimension acc. to ARI-works standard)

Weights

Figure-No.	DN	15	20	25	32	40	50	65	80	100	125	150	200	250	300	350	400	500
10.003 / 303	(kg)	2,4	2,9	3,5	4,8	6,4	8,2	12,2	18,6	27	42	67	112	--	--	--	--	--
12.003 / 303	(kg)	2,4	3	3,8	5,7	7,4	10,3	15,2	20,4	31	49	69	132	198	278	--	--	--
22.003 / 303	(kg)	3,5	4	5	6	8	11	16	21	31	49	69	132	198	278	383	--	--
23.003 / 303	(kg)	3,5	4	5	6	8	11	16	21	32	51	70	--	--	--	--	--	--
34.003 / 303	(kg)	3,8	4,9	5,9	7,1	10,4	12,3	22,7	28,5	40	64	90	160	222	337	461	709	989
35.003 / 303	(kg)	3,8	4,9	5,9	7,1	10,4	12,3	22,7	28,5	40	64	90	170	240	374	508	786	1044

Check valve - straight through with flanges (Forged steel)

Figure	Nominal pressure	Material	Nominal diameter
45.003	PN40	1.0460	DN15-50
Set pressure 0,1 bar			
Test: • German TA - Luft TÜV-Test-No. 922-9204866			

Selection of possible applications

Industry, power stations, flue gas purification plant, vapour facilities, recycling facilities, shipbuilding, general plant manufacturing
 (other applications on request)

Selection of possible flow media

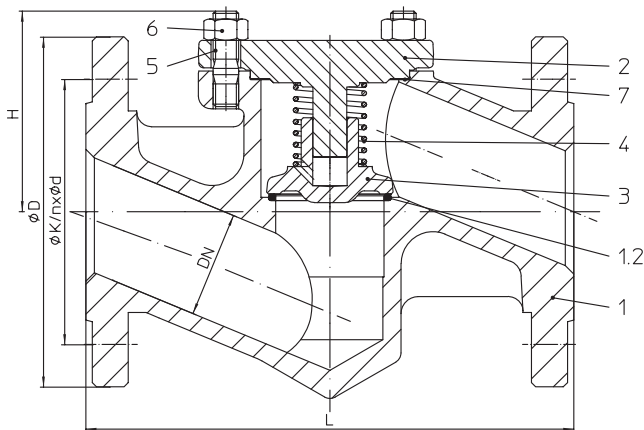
Steam, gases, liquids, etc.
 (other flow media on request)

Parts

Pos.	Description	Fig. 34./35.003
1	Body	P250 GH, 1.0460
1.2	Seat ring	G19 9 Nb Si, 1.4551
2	Cover	P250 GH, 1.0460
3	Plug	X20Cr13+QT, 1.4021+QT
4	Spring	X10CrNi18-8, 1.4310
5	Stud	25CrMo4, 1.7218
6	Hexagon nut	C35E, 1.1181
7	Gasket	Pure graphite (CrNi laminated with graphite)

Information / restriction of technical rules need to be observed!

Operating instructions can be ordered by phone +49 (0)5207 / 994-0 or fax +49 (0)5207 / 994-158 or -159.

ARI-Valves of EN-JL1040 are not allowed to be operated in systems acc. to TRD 110.

A production allowance acc. to TRB 801 No. 45 exists

The engineer, designing a system or a plant, is responsible for the selection of the correct valve.

Dimensions

	DN	15	20	25	32	40	50
L	(mm)	130	150	160	180	200	230
H	(mm)	70	70	80	80	85	95
Kvs-value	(m ³ /h)	3,3	5,5	9,2	15	29,3	36
Zeta-value	--	7,2	7,3	7,1	7,2	7,3	7,4

Zeta-value ... range of tolerance for Kvs-values acc. to VDI/VDE 2173

Standard-flange dimensions refer to page 11

Face-to-face dimension FTF series 1 according to DIN EN 558-1

Weights

Figure-No.	DN	15	20	25	32	40	50
45.003	(kg)	3,2	4,5	4,6	7,3	9,5	12

Check valve - straight through with flanges (Stainless steel)

Figure	Nominal pressure	Material	Nominal diameter
52.003	PN16	1.4408	DN65-200
54.003	PN25	1.4408	DN15-200
55.003	PN40	1.4408	DN15-200

Set pressure 0,1 bar
 Test: • German TA - Luft TÜV-Test-No. 922-9204866

Selection of possible applications

Recycling facilities, chemical industry, hospital technology, process water installations, installations with aggressive media (other applications on request)

Selection of possible flow media

Process water, aggressive media, etc. (other flow media on request)

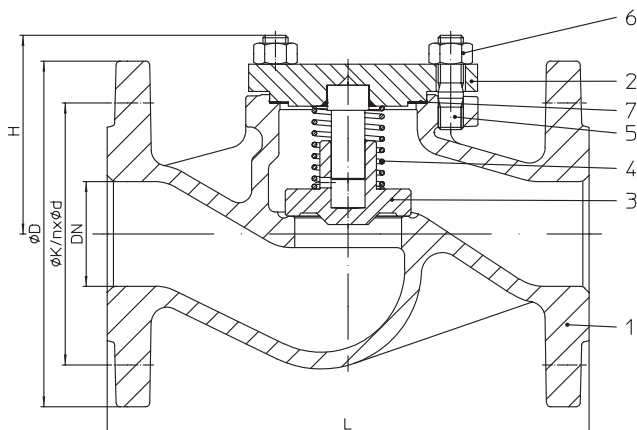
Parts

Pos.	Description	Fig. 52./54./55.003
1	Body	GX5CrNiMo19-11-2, 1.4408
2	Cover	X6CrNiMoTi17-12-2, 1.4571
3	Plug	X6CrNiMoTi17-12-2, 1.4571
4	Spring	X10CrNi18-8, 1.4310
5	Stud	A4-70
6	Hexagon nut	A4
7	Gasket	Pure graphite (CrNi laminated with graphite)

Information / restriction of technical rules need to be observed!

Operating instructions can be ordered by phone +49 (0)5207 / 994-0 or fax +49 (0)5207 / 994-158 or -159.

ARI-Valves of EN-JL1040 are not allowed to be operated in systems acc. to TRD 110.

A production allowance acc. to TRB 801 No. 45 exists

The engineer, designing a system or a plant, is responsible for the selection of the correct valve.

Dimensions

	DN	15	20	25	32	40	50	65	80	100	125	150	200	250	300	350	400	500	
L	(mm)	130	150	160	180	200	230	290	310	350	400	480	600	on request					
H	(mm)	70	70	80	80	85	95	110	130	155	165	215	285						
Kvs-value	(m ³ /h)	5,7	7,8	11,8	17,9	27,5	48,0	77,6	109	168	251	389	664						
Zeta-value	--	2,5	4,2	4,5	5,2	5,4	4,3	4,7	5,5	5,7	6,2	5,4	5,8						

Zeta-value ... range of tolerance for Kvs-values acc. to VDI/VDE 2173

Standard-flange dimensions refer to page 11

Face-to-face dimension FTF series 1 according to DIN EN 558-1

Weights

Figure-No.	DN	15	20	25	32	40	50	65	80	100	125	150	200	250	300	350	400	500	
52.003	(kg)	--	--	--	--	--	--	22,5	28,5	38	61	87	154	on request					
54.003	(kg)	3,8	4,9	5,9	7,1	10	12	22,5	28,5	40	64	90	160						
55.003	(kg)	3,8	4,9	5,9	7,1	10	12	22,5	28,5	40	64	90	170						

Check valve - angle pattern with flanges (Grey cast iron, SG iron, Cast steel)

Figure	Nominal pressure	Material	Nominal diameter
12.004 / 12.304	PN16	EN-JL1040	DN15-300
22.004 / 22.304	PN16	EN-JS1049	DN15-350
23.004 / 23.304	PN25	EN-JS1049	DN15-150
34.004 / 34.304	PN25	1.0619+N	DN15-500
35.004 / 35.304	PN40	1.0619+N	DN15-500

Set pressure 0,1 bar

Fig. 304: Trim made of RG/MS:

CuZn35Ni3Mn2AlPb, CW710R code number 02

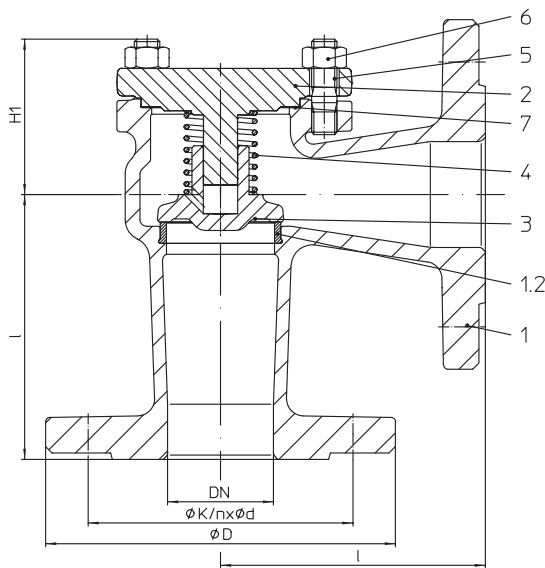
CuSn10-Cu, CC480K code number 03

(max. operating temperature: 225°C, code number acc. to DIN 86251)

Test: • German TA - Luft TÜV-Test-No. 922-9204866

Selection of possible applications

Industry, power stations, flue gas purification plant, vapour facilities, recycling facilities, shipbuilding, general plant manufacturing (other applications on request)

Selection of possible flow media

Steam, gases, liquids, etc. (other flow media on request)

Parts

Pos.	Description	Fig. 10./12.003	Fig. 10./12.303	Fig. 22./23.003	Fig. 22./23.303	Fig. 34./35.003	Fig. 34./35.303
1	Body	EN-JL1040, EN-GJL-250		EN-JS1049, EN-GJS-400-18U-LT		GP240GH+N, 1.0619+N	
1.2	Seat ring	DN ≤50: X20Cr13+QT, 1.4021+QT DN >50: G19 9 Nb Si, 1.4551	CuSn10-Cu, CC480K code number 03	DN ≤50: X20Cr13+QT, 1.4021+QT DN >50: G19 9 Nb Si, 1.4551	CuSn10-Cu, CC480K code number 03	DN ≤50: X20Cr13+QT, 1.4021+QT DN >50: G19 9 Nb Si, 1.4551	CuSn10-Cu, CC480K code number 03
2	Cover	EN-JL1040, EN-GJL-250		EN-JS1049, EN-GJS-400-18U-LT		GP240GH+N, 1.0619+N	
3	Plug	DN ≤200: X20Cr13+QT, 1.4021+QT DN >200: P265 GH, 1.0425 / G19 9 Nb Si, 1.4551	CuSn10-Cu, CC480K code number 03	DN ≤200: X20Cr13+QT, 1.4021+QT DN >200: P265 GH, 1.0425 / G19 9 Nb Si, 1.4551	CuSn10-Cu, CC480K code number 03	DN ≤200: X20Cr13+QT, 1.4021+QT DN >200: P265 GH, 1.0425 / G19 9 Nb Si, 1.4551	CuSn10-Cu, CC480K code number 03
4	Spring	X10CrNi18-8, 1.4310		X10CrNi18-8, 1.4310			
5	Hexagon bolt	5.6		--			
5	Stud	--		25CrMo4, 1.7218			
6	Hexagon nut	--		C35E, 1.1181			
7	Gasket	Pure graphite (CrNi laminated with graphite)					

Information / restriction of technical rules need to be observed!

Operating instructions can be ordered by phone +49 (0)5207 / 994-0 or fax +49 (0)5207 / 994-158 or -159.

ARI-Valves of EN-JL1040 are not allowed to be operated in systems acc. to TRD 110.

A production allowance acc. to TRB 801 No. 45 exists (acc. to TRB 801 No. 45 EN-JL1040 is not allowed.)

The engineer, designing a system or a plant, is responsible for the selection of the correct valve.

Dimensions

	DN	15	20	25	32	40	50	65	80	100	125	150	200	250	300	350	400	500
l	(mm)	90	95	100	105	115	125	145	155	175	200	225	275	325	375	425	475	525
H1	(mm)	40	35	45	45	55	60	65	95	105	120	150	195	220	240	300	310	380
Kvs-value	(m³/h)	4,8	8,5	13	22	34	53	88	138	216	331	469	832	1315	1876	2553	3406	5207
Zeta-value	--	3,4	3,4	3,3	3,2	3,4	3,3	3,5	3,3	3,2	3,4	3,5	3,5	3,4	3,4	3,5	3,3	3,5

Zeta-value ... range of tolerance for Kvs-values acc. to VDI/VDE 2173

Standard-flange dimensions refer to page 11

Face-to-face dimension CTF series 8 according to DIN EN 558-1 (DN500: Face-to-face dimension acc. to ARI-works standard)

Weights

Figure-No.	DN	15	20	25	32	40	50	65	80	100	125	150	200	250	300	350	400	500
12.004 / 304	(kg)	3	3,5	4	6	8	10	14	19	25	45	70	112	179	248	345	--	--
22.004 / 304	(kg)	3	3,5	4	6	8	10	14	19	25	45	70	112	179	248	345	--	--
23.004 / 304	(kg)	3	3,5	4,1	6	8	10	14	20	29	49	73	on request					
34.004 / 304	(kg)	4,2	4,9	5	7,6	10	12	24,5	28,5	42	55	90	145	170	225	383	623	870
35.004 / 304	(kg)	4,2	4,9	5	7,6	10	12	24,5	28,5	42	55	90	155	188	262	430	700	925

Check valve - straight through with butt weld ends (Forged steel)

Figure	Nominal pressure	Material	Nominal diameter
45.030	PN40	1.0460	DN15-50
Set pressure 0,1 bar			
Butt weld ends according to DIN EN 12627 - 4 (refer to page 10)			
Test: • German TA - Luft TÜV-Test-No. 922-9204866			

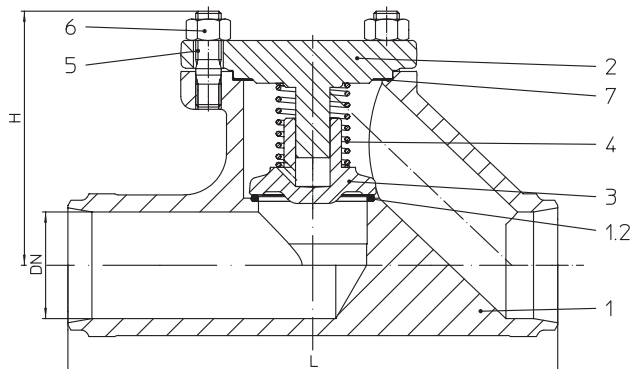
Selection of possible applications

Industry, power stations, flue gas purification plant, vapour facilities, recycling facilities, shipbuilding, general plant manufacturing (other applications on request)

Selection of possible flow media

Steam, gases, liquids, etc. (other flow media on request)

Parts

Pos.	Description	Fig. 35.030
1	Body	P250 GH, 1.0460
1.2	Seat ring	G19 9 Nb Si, 1.4551
2	Cover	P250 GH, 1.0460
3	Plug	X20Cr13+QT, 1.4021+QT
4	Spring	X10CrNi18-8, 1.4310
5	Stud	25CrMo4, 1.7218
6	Hexagon nut	C35E, 1.1181
7	Gasket	Pure graphite (CrNi laminated with graphite)

Information / restriction of technical rules need to be observed!

Operating instructions can be ordered by phone +49 (0)5207 / 994-0 or fax +49 (0)5207 / 994-158 or -159.

ARI-Valves of EN-JL1040 are not allowed to be operated in systems acc. to TRD 110.

A production allowance acc. to TRB 801 No. 45 exists

The engineer, designing a system or a plant, is responsible for the selection of the correct valve.

Dimensions

	DN	15	20	25	32	40	50
L	(mm)	130	150	160	180	200	230
H	(mm)	70	70	80	80	85	95
Kvs-value	(m ³ /h)	3,3	5,5	9,2	15	29,3	36
Zeta-value	--	7,2	7,3	7,1	7,2	7,3	7,4

Zeta-value ... range of tolerance for Kvs-values acc. to VDI/VDE 2173

Face-to-face dimension ETE series 1 according to DIN EN 12982

Weights

Figure-No.	DN	15	20	25	32	40	50
45.030	(kg)	3	3,9	4,6	5,3	8,5	9,7

Check valve - straight through with butt weld ends (Cast steel)

Figure	Nominal pressure	Material	Nominal diameter
35.030	PN40	1.0619+N	DN65-300
Set pressure 0,1 bar			
Butt weld ends according to DIN EN 12627 - 4 (refer to page 10)			
alternative: DN 65-200 with shoed ends of P235GH			
Test: • German TA - Luft TÜV-Test-No. 922-9204866			

Selection of possible applications

Industry, power stations, flue gas purification plant, vapour facilities, recycling facilities, shipbuilding, general plant manufacturing
 (other applications on request)

Selection of possible flow media

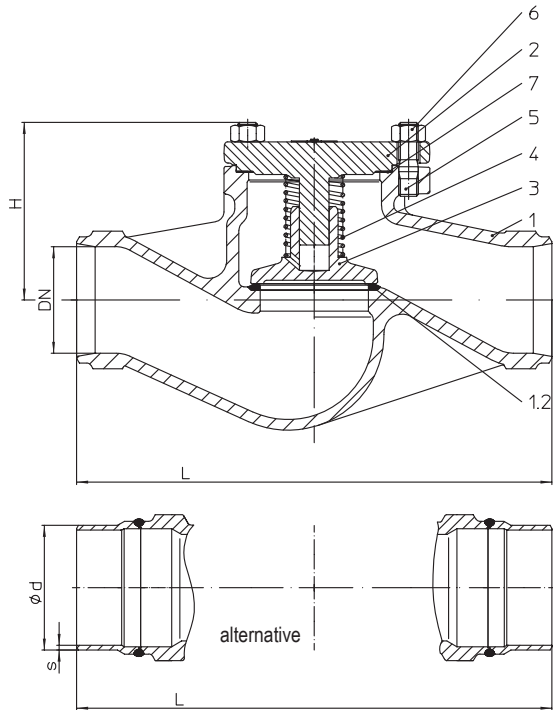
Steam, gases, liquids, etc.
 (other flow media on request)

Parts

Pos.	Description	Fig. 35.030
1	Body	GP240GH+N, 1.0619+N
1.2	Seat ring	DN ≤50: X20Cr13+QT, 1.4021+QT DN >50: G19 9 Nb Si, 1.4551
2	Cover	GP240GH+N, 1.0619+N
3	Plug	DN ≤200: X20Cr13+QT, 1.4021+QT DN >200: P265 GH, 1.0425 / G19 9 Nb Si, 1.4551
4	Spring	X10CrNi18-8, 1.4310
5	Stud	25CrMo4, 1.7218
6	Hexagon nut	C35E, 1.1181
7	Gasket	Pure graphite (CrNi laminated with graphite)

Information / restriction of technical rules need to be observed!

Operating instructions can be ordered by phone +49 (0)5207 / 994-0 or fax +49 (0)5207 / 994-158 or -159.

ARI-Valves of EN-JL1040 are not allowed to be operated in systems acc. to TRD 110.

A production allowance acc. to TRB 801 No. 45 exists)

The engineer, designing a system or a plant, is responsible for the selection of the correct valve.

Dimensions

	DN	15	20	25	32	40	50	65	80	100	125	150	200	250	300
L	(mm)	130	150	160	180	200	230	290	310	350	400	480	600	730	850
H	(mm)	70	70	80	80	85	95	110	130	155	165	215	285	325	365
Kvs-value	(m³/h)	5,7	7,8	11,8	17,9	27,5	48	77,6	109	168	251	389	664	1017	1446
Zeta-value	--	2,5	4,2	4,5	5,2	5,4	4,3	4,7	5,5	5,7	6,2	5,4	5,8	6	6,2

Zeta-value ... range of tolerance for Kvs-values acc. to VDI/VDE 2173

Face-to-face dimension ETE series 1 according to DIN EN 12982

Weights

Figure-No.	DN	65	80	100	125	150	200	250	300
35.030	(kg)	19,2	24	34	56	80	152	222	300

Check valve - Y-pattern with flanges (Stainless steel)

Figure	Nominal pressure	Material	Nominal diameter
55.039	PN40	1.4408	DN15-200
Set pressure 0,1 bar			
Test: • German TA - Luft TÜV-Test-No. 922-9204866			

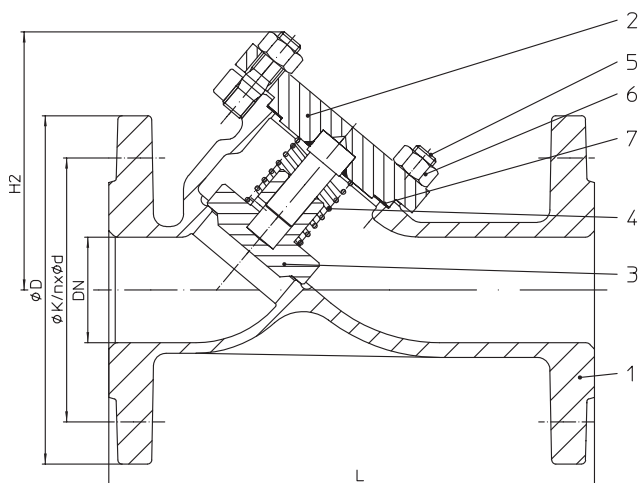
Selection of possible applications

Recycling facilities, chemical industry, hospital technology, process water installations, installations with aggressive media (other applications on request)

Selection of possible flow media

Process water, aggressive media, etc. (other flow media on request)

Parts

Pos.	Description	Fig. 55.039
1	Body	GX5CrNiMo19-11-2, 1.4408
2	Cover	X6CrNiMoTi17-12-2, 1.4571
3	Plug	X6CrNiMoTi17-12-2, 1.4571
4	Spring	X10CrNi18-8, 1.4310
5	Stud	A4-70
6	Hexagon nut	A4
7	Gasket	Pure graphite (CrNi laminated with graphite)

Information / restriction of technical rules need to be observed!

Operating instructions can be ordered by phone +49 (0)5207 / 994-0 or fax +49 (0)5207 / 994-158 or -159.

ARI-Valves of EN-JL1040 are not allowed to be operated in systems acc. to TRD 110.

A production allowance acc. to TRB 801 No. 45 exists

The engineer, designing a system or a plant, is responsible for the selection of the correct valve.

Dimensions

	DN	15	20	25	32	40	50	65	80	100	125	150	200
L	(mm)	130	150	160	180	200	230	290	310	350	400	480	600
H2	(mm)	75	75	90	90	110	110	135	160	200	245	300	390
Kvs-value	(m³/h)	4,7	7,5	14	22	40	50	81	119	181	285	397	710
Zeta-value	--	3,4	4,4	3	3,3	2,4	3,8	4,2	4,4	4,7	4,6	4,9	4,9

Zeta-value ... range of tolerance for Kvs-values acc. to VDI/VDE 2173

Standard-flange dimensions refer to page 11

Face-to-face dimension FTF series 1 according to DIN EN 558-1

Weights

Figure-No.	DN	15	20	25	32	40	50	65	80	100	125	150	200
55.039	(kg)	3,1	3,8	5	7	8,4	11	15,5	22	31	45	68	135

Check valve - Y-pattern with butt weld ends (Cast steel)

Figure	Nominal pressure	Material	Nominal diameter
35.063	PN40	1.0619+N	DN15-250
Set pressure 0,1 bar			
Butt weld ends according to DIN EN 12627 - 4 (refer to page 10)			
Test: • German TA - Luft TÜV-Test-No. 922-9204866			

Selection of possible applications

Industry, power stations, flue gas purification plant, vapour facilities, recycling facilities, shipbuilding, general plant manufacturing (other applications on request)

Selection of possible flow media

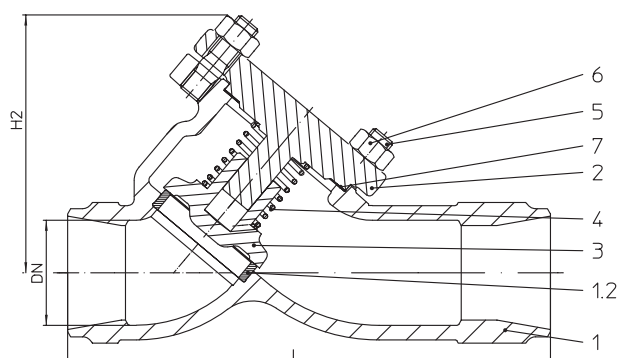
Steam, gases, liquids, etc. (other flow media on request)

Parts

Pos.	Description	Fig. 35.063
1	Body	GP240GH+N, 1.0619+N
1.2	Seat ring	DN ≤50: X20Cr13+QT, 1.4021+QT DN >50: G19 9 Nb Si, 1.4551
2	Cover	GP240GH+N, 1.0619+N
3	Plug	DN ≤200: X20Cr13+QT, 1.4021+QT DN >200: P265 GH, 1.0425 / G19 9 Nb Si, 1.4551
4	Spring	X10CrNi18-8, 1.4310
5	Stud	25CrMo4, 1.7218
6	Hexagon nut	C35E, 1.1181
7	Gasket	Pure graphite (CrNi laminated with graphite)

Information / restriction of technical rules need to be observed!

Operating instructions can be ordered by phone +49 (0)5207 / 994-0 or fax +49 (0)5207 / 994-158 or -159.

ARI-Valves of EN-JL1040 are not allowed to be operated in systems acc. to TRD 110.

A production allowance acc. to TRB 801 No. 45 exists)

The engineer, designing a system or a plant, is responsible for the selection of the correct valve.

Dimensions

	DN	15	20	25	32	40	50	65	80	100	125	150	200	250
L	(mm)	130	150	160	180	200	230	290	310	350	400	480	600	730
H2	(mm)	75	75	90	90	110	110	135	160	200	245	300	390	470
Kvs-value	(m ³ /h)	4,7	7,5	14	22	40	50	81	119	181	285	397	710	??
Zeta-value	--	3,4	4,4	3	3,3	2,4	3,8	4,2	4,4	4,7	4,6	4,9	4,9	??

Zeta-value ... range of tolerance for Kvs-values acc. to VDI/VDE 2173

Face-to-face dimension ETE series 1 according to DIN EN 12982

Weights

Figure-No.	DN	15	20	25	32	40	50	65	80	100	125	150	200	250
35.063	(kg)	2,3	2,4	3,1	3,4	4,5	5,7	9,8	13,3	20	25,5	43,8	140	162

L = Face-to-face dimension
 Edge shaping acc. to DIN EN 25817

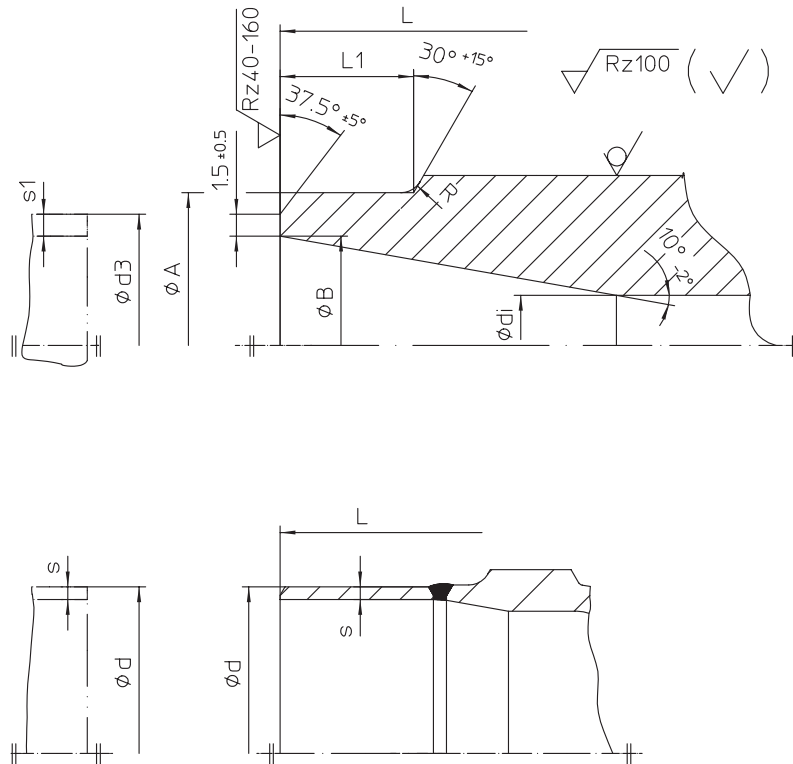

Butt weld ends acc. to DIN EN 1262 -4

	DN	15	20	25	32	40	50	65	80	100	125	150	200	250	300	350	400
L	(mm)	130	150	160	180	200	230	290	310	350	400	480	600	730	850	980	1100
ØA	(mm)	22	28	35	44	50	62	77	91	117	144	172	223	278	329	362	413
ØB	(mm)	17,3	22,3	28,5	37,2	43,1	53,9	68,9	80,9	104,3	130,7	157,1	204,9	257,0	307,9	338,0	384,4
Ødi	(mm)	15	20	25	32	40	50	65	80	100	125	150	200	250	300	330	375
R	(mm)	3	3	3	3	3	3	3	3	3	3	3	5	5	5	5	5
L1	(mm)	10	10	10	10	10	10	10	12	14	18	20	20	25	33	45	45
Ød3	(mm)	21,3	26,9	33,7	42,4	48,3	60,3	76,1	88,9	114,3	139,7	168,3	219,1	273,0	323,9	355,6	406,4
s1	(mm)	2,0	2,3	2,6	2,6	2,6	3,2	3,6	4,0	5,0	4,5	5,6	7,1	8,0	8,0	8,8	11,0

Shoed ends of P235GH (Pipe connection ≙ welding neck flanges)

	DN	15	20	25	32	40	50	65	80	100	125	150	200	250	300	350	400
Ød	(mm)	--	--	--	--	--	--	76,1	88,9	114,3	139,7	168,3	219,1	--	--	--	--
Øs	(mm)	--	--	--	--	--	--	2,9	3,2	3,6	4,0	4,5	6,3	--	--	--	--

Face-to-face dimension acc. to DIN EN 12982 ETE-1

Butt weld ends acc. to DIN EN 1262 -4

Weld joint according to DIN EN 29692 code number 1.3.3

The material used for ARI valves with butt weld ends are:

GP240GH+N, 1.0619+N acc. to DIN EN 10213-2,

P250 GH, 1.0460 acc. to DIN EN 10222-2.

The material used for ARI valves with shoed ends (DN 65-200) P235GH according to DIN EN 10216-2.

Based on our experience we recommend electric welding process for connecting valves or strainers with tubes or with each other

Lime based electrodes with an appropriate composite material should be used as filler material for welding.

Gas welding should be avoided.

Because of the different material compositions and wall thickness of the steam traps and the pipe gas welding shall not be applied. Quenching cracks and coarse grain structure may develop..

Standard-flange dimensions

Flanges acc. to DIN EN 1092-1/2 (Flangeholes / -thickness tol. acc. to DIN 2533/2544/2545)

DN		(mm)	15	20	25	32	40	50	65	80	100	125	150	200	250	300	350	400	500
PN6	ØD	(mm)	80	90	100	120	130	140	160	190	210	240	265	320	--	--	--	--	--
PN6	ØK	(mm)	55	65	75	90	100	110	130	150	170	200	225	280	--	--	--	--	--
PN6	n x Ød	(mm)	4x11	4x11	4x11	4x14	4x14	4x14	4x14	4x18	4x18	8x18	8x18	8x18	--	--	--	--	--
PN16	ØD	(mm)	95	105	115	140	150	165	185	200	220	250	285	340	405	460	520	580	715
PN16	ØK	(mm)	65	75	85	100	110	125	145	160	180	210	240	295	355	410	470	525	650
PN16	n x Ød	(mm)	4x14	4x14	4x14	4x18	4x18	4x18	4x18	8x18	8x18	8x18	8x22	12x22	12x26	12x26	16x26	16x30	20x33
PN25	ØD	(mm)	95	105	115	140	150	165	185	200	235	270	300	360	425	485	555	620	730
PN25	ØK	(mm)	65	75	85	100	110	125	145	160	190	220	250	310	370	430	490	550	660
PN25	n x Ød	(mm)	4x14	4x14	4x14	4x18	4x18	4x18	8x18	8x18	8x22	8x26	8x26	12x26	12x30	16x30	16x33	16x36	20x36
PN40	ØD	(mm)	95	105	115	140	150	165	185	200	235	270	300	375	450	515	580	660	755
PN40	ØK	(mm)	65	75	85	100	110	125	145	160	190	220	250	320	385	450	510	585	670
PN40	n x Ød	(mm)	4x14	4x14	4x14	4x18	4x18	4x18	8x18	8x18	8x22	8x26	8x26	12x30	12x33	16x33	16x36	16x39	20x42

Pressure-temperature-ratings acc. to DIN EN 1092-2

Material	PN		-60°C to <-10°C	-10°C to 120°C	150°C	200°C	250°C	300°C	350°C	400°C	450°C
EN-JL1040	6	bar	--	6	5,4	4,8	4,2	3,6	--	--	--
EN-JL1040	16	bar	--	16	14,4	12,8	11,2	9,6	--	--	--
EN-JS1049	16	bar	on request	16	15,5	14,7	13,9	12,8	11,2	--	--
EN-JS1049	25	bar	on request	25	24,3	23	21,8	20	17,5	--	--

Pressure-temperature-ratings acc. to DIN EN 1092-1

Material	PN		-60°C to <-10°C	-10°C to 50°C	100°C	150°C	200°C	250°C	300°C	350°C	400°C	450°C
1.0619+N	25	bar	18,7	25	23,3	21,7	19,4	17,8	16,1	15	14,4	13,9
1.0619+N	40	bar	30	40	37,3	34,7	30,2	28,4	25,8	24	23,1	22,2
1.0460	25	bar	18,7	25	23,3	21,7	19,4	17,8	16,1	15	14,4	10
1.0460	40	bar	30	40	37,3	34,7	30,2	28,4	25,8	24	23,1	16
1.4408	16	bar	16	16	14,9	13,5	12,4	11,7	11	10,7	10,2	--
1.4408	25	bar	25	25	23,3	21,1	19,4	18,3	17,2	16,7	16	--
1.4408	40	bar	40	40	37,3	33,8	31,1	29,3	27,6	26,7	25,6	--

Intermediate values for max. permissible operational pressures can be determined by linear interpolation of the given temperature / pressure chart.

* Studs and nuts made of A4-70 (at temperatures below -10°C)

Please indicate when ordering

- Figure-No.
- Nominal pressure
- Nominal diameter
- Special design / accessories

Example:

Figure 35.003; nominal pressure PN40; nominal diameter DN100.

 Dimensions in mm
 Weights in kg
 1 bar $\hat{=}$ 10⁵ Pa $\hat{=}$ 0,1 MPa
 Kvs in m³/h

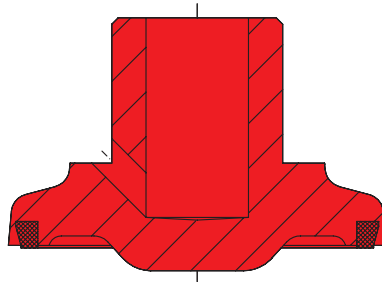

Soft sealing disc
Max. operating temperature 200°C at PTFE + 25% carbon

Check valve with damper

In special applications, like high flow turbulences, check valves with damper should be used:

- if check valves are mounted directly by centrifuged pumps;
- behind pressure reduction stations;
- behind pipe elbows;
- in compact plants;
- if expansion joints are missing;
- if the pump is not mounted on a damper;
- if there is no flow stabilizing pipe dimension;
- if there is no start-up bypass line;
- when chosen valve diameter to large.

Working principle

The precise tolerance between shaft and plug hole prevents an abrupt displacement of medium out of the plug..

